

Installation Manual

5459000F

60 Hz

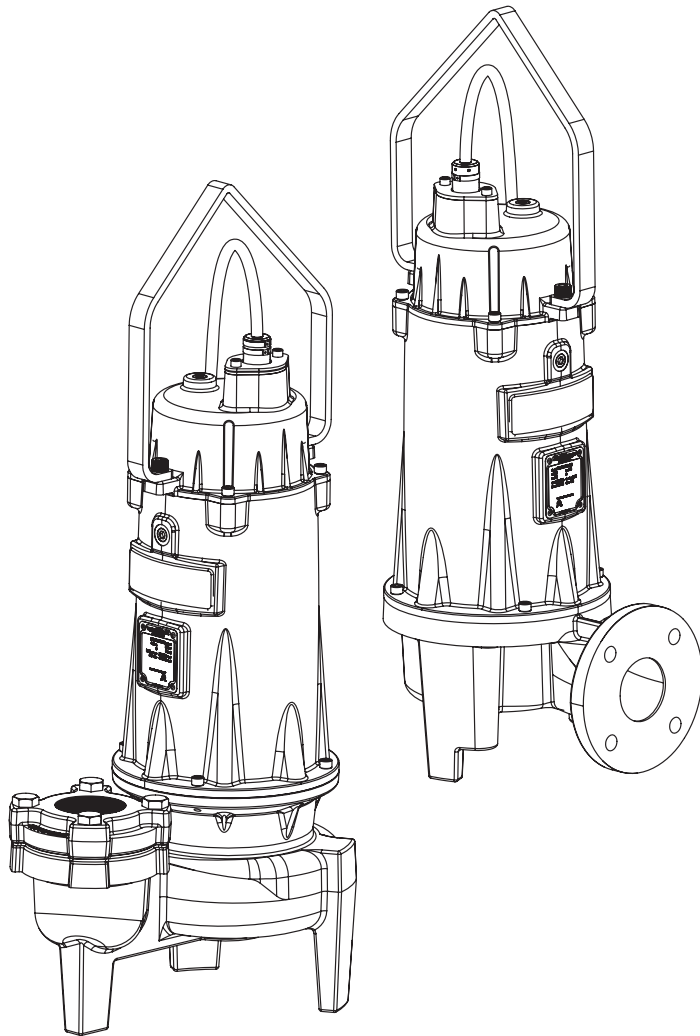

2LE-Series

Open 2 Vane
1.5–5 hp
2.5" Solids Handling

3LEV-Series

Vortex
1.5–5 hp
3" Solids Handling

Sewage Pumps

NOTICE

Installer: manual must remain with owner or system operator/maintainer.

Record information from pump nameplate:

Model: _____

Serial: _____

Control Panel: _____

Mfg Date: _____

Install Date: _____

Dealer: _____

Dealer Ph: _____



Liberty Pumps®





Engineered **Products**

7000 Apple Tree Avenue
Bergen, NY 14416
ph: 1-800-543-2550
fax: 1-585-494-1839
www.LibertyPumps.com/LEP

Contents

Safety Precautions	2 EN
General Information	4 EN
Operating Constraints	4 EN
Model Specifications	4 EN
Inspection and Storage	4 EN
Pump System Components	4 EN
Wiring Instructions	5 EN
Preparation	6 EN
Installation	7 EN
Operation	8 EN
Maintenance and Troubleshooting	8 EN
Warranty	12 EN

Safety Guidelines

	This safety alert symbol is used in the manual and on the pump to alert of potential risk for serious injury or death.
	This safety alert symbol identifies risk of electric shock . It is accompanied with an instruction intended to minimize potential risk of electric shock.
	This safety alert symbol identifies risk of fire . It is accompanied with an instruction intended to minimize potential risk of fire.
	This safety alert symbol identifies risk of serious injury or death . It is accompanied with an instruction intended to minimize potential risk of injury or death.
⚠ DANGER	Warns of hazards which if not avoided will result in serious injury or death.
⚠ WARNING	Warns of hazards which if not avoided could result in serious injury or death.
⚠ CAUTION	Warns of hazards which if not avoided could result in minor or moderate injury.
NOTICE	Signals an important instruction related to the pump. Failure to follow these instructions could result in pump failure or property damage.

⚠ WARNING Read every supplied manual before using pump system. Follow all the safety instructions in manual(s) and on the pump. Failure to do so could result in serious injury or death.

Safety Precautions

⚠ WARNING **RISK OF ELECTRIC SHOCK**

- Always disconnect pump(s) from power source(s) before handling or making any adjustments to either the pump(s), the pump system, or the control panel.
- Accidental contact with electrically live parts, items, fluid, or water can cause serious injury or death.
- All installation and maintenance of pumps, controls, protection devices, and general wiring shall be done by qualified personnel.
- All electrical and safety practices shall be in accordance with the National Electrical Code[®], the Occupational Safety and Health Administration, or applicable local codes and ordinances.
- Do not remove cord and strain relief, and do not connect conduit to pump.
- Pump shall be properly grounded using its supplied grounding conductor. Do not bypass grounding wires or remove ground prong from attachment plugs. Failure to properly ground the pump system can cause all metal portions of the pump and its surroundings to become energized.
- Do not handle or unplug the pump with wet hands, when standing on damp surface, or in water unless wearing Personal Protective Equipment.
- Always wear dielectric rubber boots and other applicable Personal Protective Equipment (PPE) when water is on the floor and an energized pump system must be serviced, as submerged electrical connections can energize the water. Do not enter the water if the water level is higher than the PPE protection or if the PPE is not watertight.
- Do not lift or carry a pump or a float assembly by its power cord. This will damage the power cord, and could expose the electrically live wires inside the power cord.
- The electrical power supply shall be located within the length limitations of the pump power cord, and for below grade installations it shall be at least 4 ft (1.22 m) above floor level.
- Do not use this product in applications where human contact with the pumped fluid is common (such as swimming pools, fountains, marine areas, etc.).
- Protect the power and control cords from the environment. Unprotected power and control (switch) cords can allow water to wick through ends into pump or switch housings, causing surroundings to become energized.
- Single-phase 200/230V pumps shall only be operated without the float switch by using the circuit breaker or panel disconnect.
- Some products may have internal capacitors that could cause shock. Avoid contact with plug ends after removing from energy source.

⚠️ WARNING**RISK OF FIRE**

- Do not use an extension cord to power the product. Extension cords can overload both the product and extension cord supply wires. Overloaded wires will get very hot and can catch on fire.
- This product requires a separate, properly fused and grounded branch circuit, sized for the voltage and amperage requirements of the pump, as noted on the nameplate. Overloaded branch circuit wires will get very hot and can catch on fire. When used, electrical outlets shall be simplex of the appropriate rating.
- For cord replacement: power cord must be of the same length and type as originally installed on the Liberty Pumps product. Use of incorrect cord may lead to exceeding the electrical rating of the cord and could result in death, serious injury, or other significant failure.
- Do not use this product with or near flammable or explosive fluids such as gasoline, fuel oil, kerosene, etc. If rotating elements inside pump strike any foreign object, sparks may occur. Sparks could ignite flammable liquids.
- Sewage and effluent systems produce and may contain flammable and explosive gases. Prevent introduction of foreign objects into basin as sparks could ignite these gases. Exercise caution using tools and do not use electronic devices or have live, exposed electrical circuits in or around basins, open covers and vents.
- These pumps are not to be installed in locations classified as hazardous in accordance with the National Electric Code[®], ANSI/NFPA 70.

⚠️ WARNING**RISK OF SERIOUS INJURY OR DEATH**

- Energizing the control panel or breaker for the first time is potentially dangerous. Licensed electrical personnel should be present when the panel or breaker is energized for the first time. If faults caused by damage or poor installation practices have not been detected, serious damage, injury or death can result when power is applied.
- Do not modify the pump/pump system in any way. Modifications may affect seals, change the electrical loading of the pump, or damage the pump and its components.
- All pump/pump system installations shall be in compliance with all applicable Federal, State, and Local codes and ordinances.
- Do not allow children to play with the pump system.
- Do not allow any person who is unqualified to have contact with this pump system. Any person who is unaware of the dangers of this pump system, or has not read this manual, can easily be injured by the pump system.
- In 200/230V installations, one side of the line going to the pump is always “hot”, whether the float switch is on or off. To avoid hazards, install a double pole disconnect near the pump installation.
- Vent basin in accordance with local code. Proper venting of sewer and effluent gases alleviates poisonous gas buildup and reduces the risk of explosion and fire from these flammable gases.

- Wear adequate Personal Protective Equipment when working on pumps or piping that have been exposed to wastewater. Sump and sewage pumps often handle materials that can transmit illness or disease upon contact with skin and other tissues.
- Do not enter a pump basin after it has been used. Sewage and effluent can emit several gases that are poisonous.
- Do not remove any tags or labels from the pump or its cord.
- Keep clear of suction and discharge openings. To prevent injury, never insert fingers into pump while it is connected to a power source.
- Do not use this product with flammable, explosive, or corrosive fluids. Do not use in a flammable and/or explosive atmosphere as serious injury or death could result.
- This product contains chemicals known to the State of California to cause cancer and birth defects or other reproductive harm. www.p65warnings.ca.gov.

⚠️ CAUTION

- ◆ This pump has been evaluated for use with water only, however use with human waste and toilet paper is permitted.

NOTICE

- ◆ Verify 3-phase pumps for correct rotation prior to installing pump(s) in basin. To change rotation, reverse any two of the three power leads to the pump (not the ground). Code the wires for reconnection after installation.
- ◆ Do not dispose of materials such as paint thinner or other chemicals down drains. Doing so could chemically attack and damage pump system components and cause product malfunction or failure.
- ◆ Do not use pumps with fluid over 104°F (40°C). Operating the pump in fluid above this temperature can overheat the pump, resulting in pump failure and excessive cavitation.
- ◆ Do not use pump system with mud, sand, cement, hydrocarbons, grease, or chemicals. Pump and system components can be damaged from these items causing product malfunction or failure. Additionally, flooding can occur if these items jam the impeller or piping.
- ◆ Do not introduce any consumer item that is not toilet paper into a non-grinder (dewatering, effluent, sewage) pump/pump system. This includes, but is not limited to the following: feminine products, wipes, towels, towelettes, dental floss, swabs, pads, etc. Items such as these put the pump under undo strain and can result in pump/pump system failure. Additionally, it creates conditions for discharge line blockage.
- ◆ Submersible Pump—do not run dry.
- ◆ The Uniform Plumbing Code[®] states that sewage systems shall have an audio and visual alarm that signals a malfunction of the system, to reduce the potential for property damage.
- ◆ Keep pump upright.
- ◆ At no time shall the pump be stored within an incomplete wet pit. The pump shall not be placed into the pit until it can be fully operational.

General Information

Before installation, read these instructions carefully. Each Liberty Pumps product is individually factory tested to ensure proper performance. Closely following these instructions will eliminate potential operating problems, assuring years of trouble-free service.

These LEP-Series pumps are to be used for handling septic tank effluent, sewage, and drain (storm) water.

Provide pump serial number in all correspondence and reports.

Complete the Start-Up Report as installation progresses. Completed and submitted Report is required for warranty. Retain Report for reference. www.libertypumps.com/lep/dom/Services/Warranty-Startup-Form

Pumps are certified by CSA® Group to CSA and UL® standards.

Pumps must be serviced at a qualified repair facility approved by Liberty Pumps. No repair work should be carried out during the warranty period without prior factory approval. Any unauthorized field repairs void warranty. Contact Liberty Pumps at 1-800-543-2550 to locate the closest authorized service center.

Operating Constraints

It is extremely important to verify that the pump has been sized correctly for the intended installation. The operating point of the pump must lie within the acceptable range as outlined by the applicable Liberty Pumps performance chart. Operating the pump outside of the recommended range can invalidate the CSA Certification of the pump and can also cause damage and premature failure. Operating outside of the recommended range can cause the pump to exceed its rated nameplate amp draw, which will void the pump certification. It can also cause motor overheating, cavitation, excessive vibration, clogging, and poor energy efficiency.

Model Specifications

For complete listing of models and their specifications, refer to www.LibertyPumps.com/lep/About/Engineering-Specs. Pump nameplate provides a record of specific pump information.

Inspection and Storage

Initial Inspection

The pump should be immediately inspected for damage that may have occurred in shipment.

1. Visually check the pump and any spare parts for damage.
2. Check for damaged electrical wires, especially where they exit the motor housing.

Contact Liberty Pumps customer service to report any damage or shortage of parts.

Storage Before Use

⚠ WARNING **RISK OF ELECTRIC SHOCK**

- Protect the power and control cords from the environment. Unprotected power and control (switch) cords can allow water to wick through ends into pump or switch housings, causing surroundings to become energized.

NOTICE

- ◆ At no time shall the pump be stored within an incomplete wet pit. The pump shall not be placed into the pit until it can be fully operational.

LEP-Series pumps are shipped from the factory ready for installation and use. The pump shall be held in storage if the pump station is not complete. If storage is necessary, the pump should remain in its shipping container. It should be stored in a warehouse or storage shed that has a clean, dry temperature-stable environment where the pump and its container shall be covered to protect it from water, dirt, vibration, etc. The cord ends must be protected against moisture. Do not allow the pump to freeze.

Uninstalled pumps that are idle for periods of time greater than three months should have impellers manually rotated once a month to lubricate the seals.

Pump System Components

Control Panel

All LEP-Series pumps require a separate, approved pump control panel for automatic operation. Operation of these models will be according to the control selected; see separate operation instructions supplied with the unit.

IMPORTANT: Verify the electrical specifications for the control panel properly match those of the pump. When connecting an LEP-Series pump to an existing control panel, verify the panel is correctly sized for the pump.

Single-phase models require run capacitors. Models with internal capacitors are factory installed; while external capacitor models (ending in -C) require run capacitors to be installed in the control panel. Refer to Table 1 for external model capacitors.

Table 1. 1-Phase External Capacitor Kits

HP	Component Specification	Liberty Pumps P/N	Mfg P/N
1.5 & 2	(x2) Oil-filled Capacitors 40 μ F 370 VAC	K001745	CDE SFS37T40K384B-0001
3	(x2) Oil-filled Capacitors 50 μ F 370 VAC	K001746	CDE SFS37T50K384B-0003
5	(x2) Oil-filled Capacitors 60 μ F 370 VAC	K001747	CDE SFS37T60K384B-0000

Overload Protection

LEP-Series pumps require overload protection in the control panel. The motor control unit shall be approved and shall be properly sized or adjusted for the full load input power indicated on the pump nameplate. It is important to properly adjust or select the motor control overload protection. The full load amperes on the nameplate should be used as a baseline, but it is important to consider that events such as supply voltage variation or large solids passing through the pump can temporarily increase current draw. To avoid possible nuisance tripping, it may be necessary to adjust overloads to a value slightly higher than the full load input power indicated on the pump nameplate.

Power Cord

⚠️ RISK OF ELECTRIC SHOCK

- Do not remove cord and strain relief, and do not connect conduit to pump.
- Each cord has a green lead. This is the ground wire and must be grounded properly per NEC[®] and/or local codes.

The power cord is a field-replaceable Standard Quick-connect cord. The cord shall not be spliced, although a junction box may be used.

Wiring Instructions

⚠️ RISK OF ELECTRIC SHOCK

- Always disconnect pump(s) from power source(s) before handling or making any adjustments to either the pump(s), the pump system, or the control panel.
- All installation and maintenance of pumps, controls, protection devices, and general wiring shall be done by qualified personnel.
- All electrical and safety practices shall be in accordance with the National Electrical Code[®], the Occupational Safety and Health Administration, or applicable local codes and ordinances.

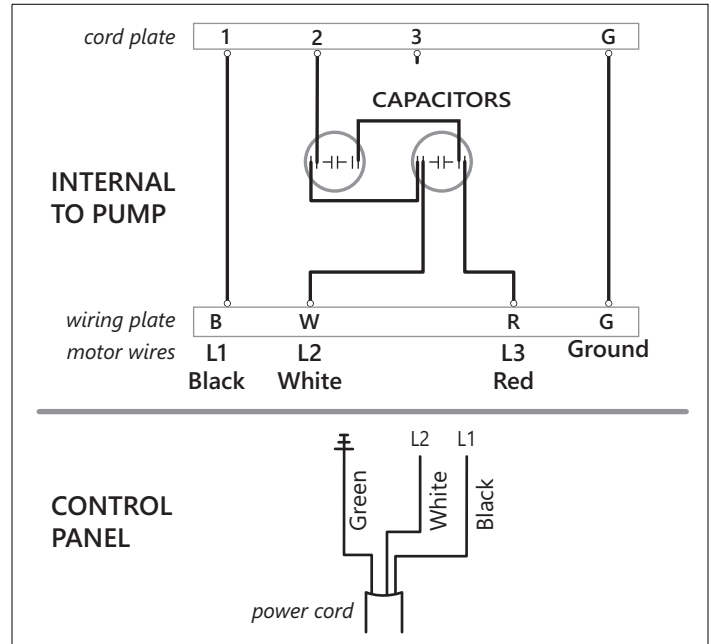

Figure 1. Wiring Diagram for 1-phase with Internal Caps

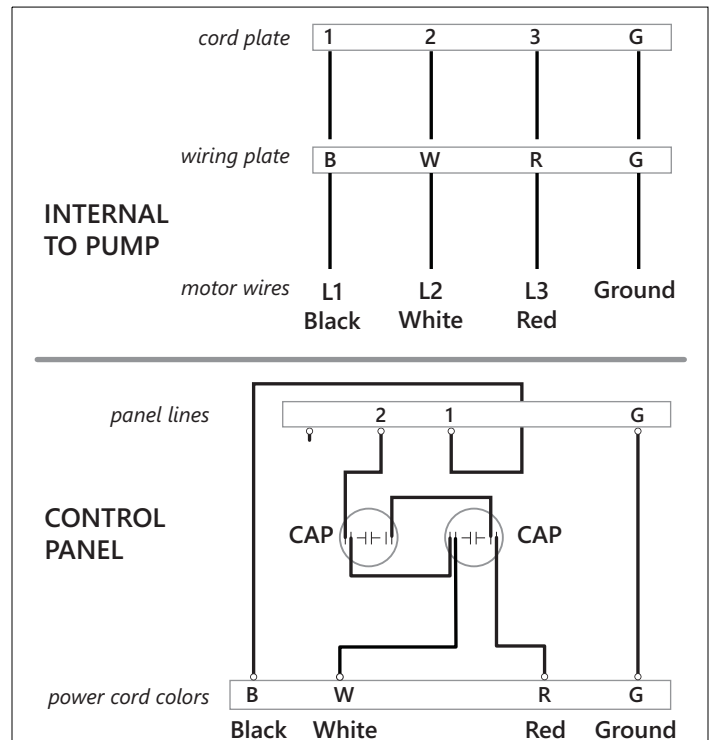

Figure 2. Wiring Diagram for 1-phase with External Caps

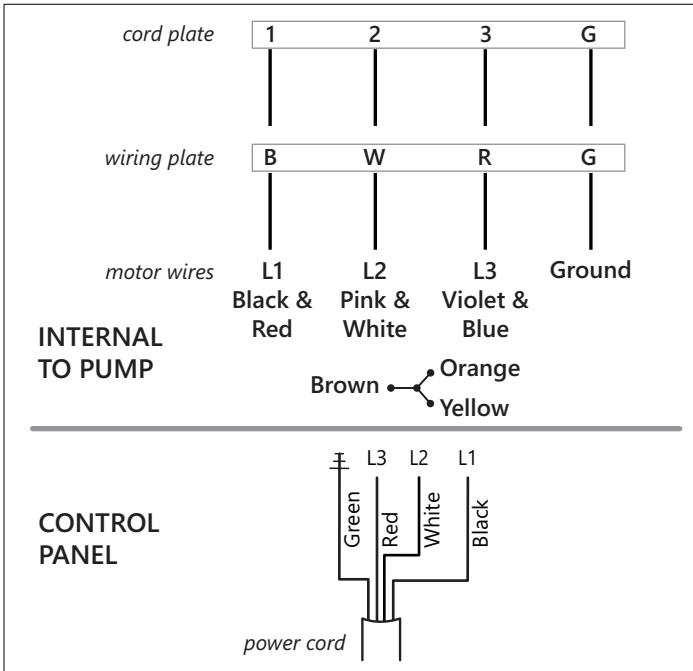

Figure 3. Wiring Diagram for 200/230V 3-phase

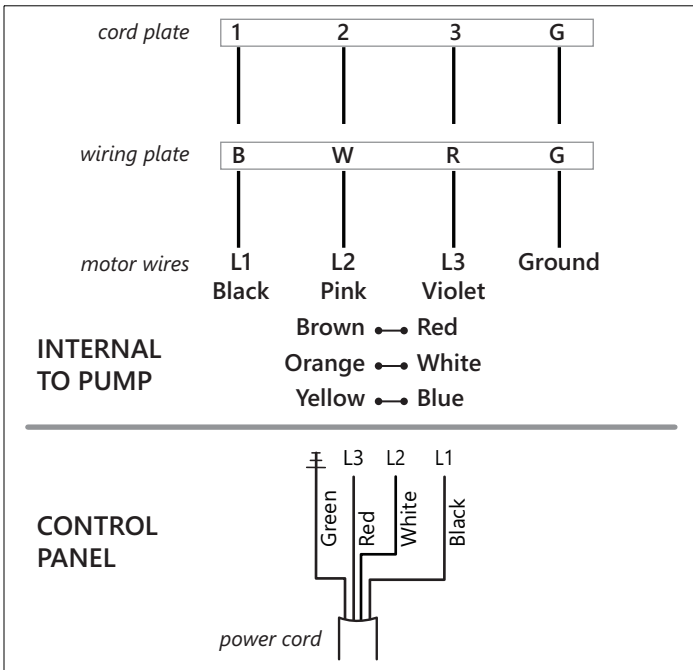

Figure 4. Wiring Diagram for 460V 3-phase

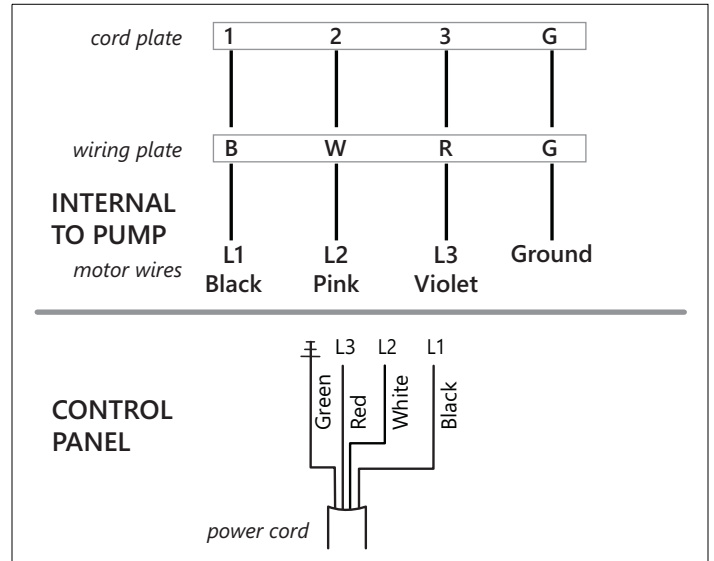

Figure 5. Wiring Diagram for 575V 3-phase

Preparation

⚠ WARNING RISK OF ELECTRIC SHOCK

- Always disconnect pump(s) from power source(s) before handling or making any adjustments to either the pump(s), the pump system, or the control panel.

Prepare Basin

The basin required for effluent and sewage applications must be sealed and vented to meet health and plumbing code requirements. If replacing a previously installed pump, prepare the basin by removing the old pump and cleaning any debris from the basin. Inspect all remaining equipment in the basin including guide rails, piping, valves, and electrical junction boxes (if present) and repair or replace as appropriate. Ensure that control hardware such as floats or pressure transducers are clean, properly adjusted, and in good working order.

Pump installation should be at a sufficient depth to ensure that all plumbing is below the frost line. If this is not feasible, remove the check valve and size the basin and/or adjust pump differential to accommodate the additional backflow volume. Consult Liberty Pumps for details on how this should be done.

Impeller Free Movement Check

Do not connect any power to pump until this check is complete. Manually rotate the impeller to check that it spins freely with very little resistance. The impeller can be rotated by reaching into the pump intake. The pump can remain upright or can be laid down on its side for easier access to the intake. Besides verification that the impeller is freely spinning, rotating the impeller helps to lubricate the shaft seals if the pump has been non-operational for more than a week. It is recommended to rotate the impeller 5–10 full rotations.

Install Pump Control and Alarm Floats

The water level in the basin is determined by the placement of the control floats and should be positioned such that the motor housing is completely submerged to properly cool the motor. The upper water level should be positioned to minimize pump starts. The alarm float should be above the turn-on float switch but below any inlets.

Set the second (turn-on) control above the lower turn-off control. The exact distance between the two floats must be a compromise between a frequent pumping cycle (30 starts per hour max.) to properly manage sewage level, and a longer pump run duration per start which maximizes energy efficiency. This distance shall be determined by the engineer, depending on the conditions of the application.

Installation

⚠️ WARNING RISK OF ELECTRIC SHOCK

- All installation and maintenance of pumps, controls, protection devices, and general wiring shall be done by qualified personnel.
- All electrical and safety practices shall be in accordance with the National Electrical Code®, the Occupational Safety and Health Administration, or applicable local codes and ordinances.

Electrical Connections

With mains power disconnected, complete pump and control wiring connections per wiring diagrams included with the control panel and *Wiring Instructions* section. Verify connections. Check all wires for unintentional grounds after connections are made.

Discharge

Make all discharge connections. A check valve is required to prevent the backflow of liquid after each pumping cycle. A gate valve should follow the check valve to allow periodic cleaning of the check valve or removal of the pump. The remainder of the discharge line shall be as short as possible with a minimum number of turns, to minimize friction head loss. Do not reduce the discharge to below the pump outlet size. Larger pipe sizes may be required to eliminate friction head loss over long runs. Contact Liberty Pumps or other qualified person if questions arise regarding proper pipe size and flow rates.

Vent

The basin provided with the system must be completely sealed and properly vented per local health and plumbing code requirements. If the system is to be vented through the inlet to an existing building vent stack, there must be no traps between the system inlet and the nearest building vent stack connection (option 1). If this is not possible or desirable per the application, a standalone vent can be installed in tank side (option 2) or a vent flange or grommet can be installed in a hole cut into the cover (option 3).

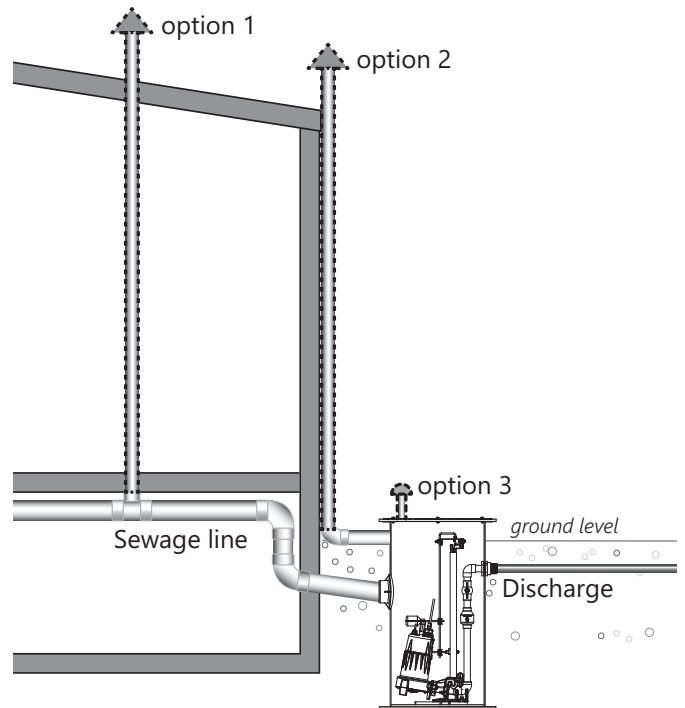

3-Phase Pump Rotation Verification

NOTICE

- ◆ Check 3-phase pumps for correct rotation prior to installing pump(s) in basin. To change rotation, reverse any two of the three power leads to the pump (not the ground). Label the wires for reconnection after installation.

Correct Impeller Rotation

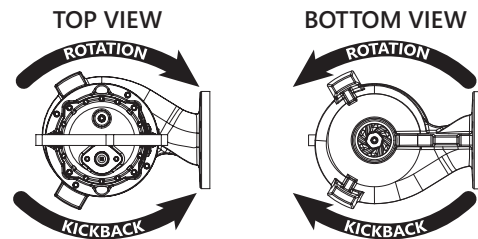

3-phase power uses three separate alternating currents that peak at different integrals. With pumps that are powered by 3-phase electric, the phase sequence of the motor must match the phase sequence of the power source. When the phase sequences match, the pump operates properly. However, when the phases are out of order, the pump runs backwards (i.e., the impeller rotates in the wrong direction). This causes an extreme loss of performance and could raise the current draw, which could result in tripping an overload or circuit breaker.

To ensure that the power to the pump is installed correctly, always verify proper rotation **before** lowering it into the basin. If the pump is rotating in the wrong direction, turn off the power and reverse any two leads. This reverses the phase sequence and corrects the pump rotation. **For 3-phase pumps, rotation must be clockwise when looking from the top of the pump. The correct direction is also stamped on the bottom of the volute.**

Inlet

Connect the inlet line to the inlet hub per engineer's specifications.

Guide Rail System

If guide rails are used, refer to the separate instructions supplied with the unit for proper installation and operation, making sure all gaskets and components are present. Contact Liberty Pumps for available models GR3 and GR4.

If guide rails are not used, complete all pump-mounted plumbing at this time, being sure all gaskets and components are present.

Operation

WARNING **RISK OF SERIOUS INJURY OR DEATH**

- Energizing the control panel or breaker for the first time is potentially dangerous. Licensed electrical personnel should be present when the panel or breaker is energized for the first time. If faults caused by damage or poor installation practices have not been detected, serious damage, injury or death can result when power is applied.

Starting System

1. Double check all wire connections.
2. Turn pump(s) to OFF position on H-O-A switch.
3. Turn on breakers.
4. Test each pump separately in HAND mode and observe operation. If 3-phase pump is noisy or vibrates, rotation is wrong. Refer to *3-Phase Pump Rotation Verification*.
5. Set H-O-A switch(es) to AUTO position and allow water to rise in basin until one pump starts. Allow pump to operate until the level drops to turn-off point.
6. Allow basin level to rise to start other pump(s). Notice run lights in panel. Pumps should alternate on each successive cycle of operation.
7. Turn H-O-A switch(es) to OFF position and allow basin to fill to the override (alarm) control level(s).
8. Observe all floats in operation to verify that there is adequate clearance to the surrounds to ensure that the floats do not have the opportunity to get hung up in their travel.
9. Verify alarm system response.
10. Turn switch(es) to AUTO position; pumps should start and operate together until level drops to turn-off point.
11. Repeat this operation and cycle several times before leaving the site.
12. Check voltage when pumps are operating and record the amp draw of each pump. Check amps on each wire as sometimes a high leg will exist. For excessive voltage on one leg, the electric utility company shall be consulted.
13. Complete Startup Report.

Be certain to complete adequate testing, especially on systems with multiple pumps or custom control configurations.

Maintenance and Troubleshooting

WARNING **RISK OF ELECTRIC SHOCK**

- Accidental contact with electrically live parts, items, fluid, or water can cause serious injury or death.
- Always disconnect pump(s) from power source(s) before handling or making any adjustments to either the pump(s), the pump system, or the control panel.

WARNING **RISK OF SERIOUS INJURY OR DEATH**

- Do not enter a pump basin after it has been used. Sewage and effluent can emit several gases that are poisonous.
- Wear adequate Personal Protective Equipment when working on pumps or piping that have been exposed to wastewater. Sump and sewage pumps often handle materials that can transmit illness or disease upon contact with skin and other tissues.

NOTICE

- ◆ Replacement impellers must match the part number of original impeller installed from the factory. Do not trim impellers without consulting the factory.
- ◆ Verify correct 3-phase pump rotation before returning to service.

Maintenance

As the motor is oil-filled, no lubrication or other maintenance is required. If replacement lubrication is required, use ISO VG 10 turbine oil (Liberty Pumps part number *LPOILT1032OZ*). Contact Liberty Pumps to purchase quart quantities. Use approximately 1.4 gallons, ensuring upper motor bearing is submerged in oil.

To keep the pump/pump system operating smoothly, perform the following routine checks. Severe operating environments will require more frequent checks. For any issues that are not resolvable, contact Liberty Pumps for further assistance.

Monthly

1. Pumps that are idle for more than a month in a dry basin should have impellers manually operated through the breaker panel monthly to lubricate the seals. **Limit the lubrication run time to less than one minute per pump.**
2. Pumps that are idle in a wet basin must be removed—**do not store pump in wet basin.**

Quarterly

1. Check pump for corrosion and wear.
2. Check for free and unobstructed float switch operation and float switch condition.
3. Inspect for proper check valve operation.
4. For multiple pumps, check for balanced operating times. Uneven times indicate a defective unit, float switch or control.
5. Inspect the control panel for any presence of moisture in enclosure, loose connections, and general component condition.

Annually

1. Basin should be inspected and cleaned. Replace any defective components.

No repair work shall be carried out during the warranty period without prior factory approval. To do so may void the warranty.

Liberty Pumps, Inc. assumes no responsibility for damage or injury due to disassembly in the field. Disassembly, other than at Liberty Pumps or its authorized service centers, automatically voids warranty.

Troubleshooting

Refer to Table 2 for help troubleshooting issues.

Table 2. Troubleshooting Matrix

Problem	Possible Cause	Corrective Action
Pump does not start.	Damaged power cord.	Replace as needed.
	Control panel selector switch in OFF position.	Set selector switch to Hand or Auto position.
	Blown control circuit transformer fuse.	Replace fuse.
	Tripped circuit breaker, blown fuse, or other interruption of power.	Reset tripped circuit breaker, replace blown fuse with properly sized fuse, check that the unit is securely plugged in, investigate power interruption.
	Improper voltage.	Have an electrician check all wiring for proper connections and adequate voltage and capacity.
	Float switch unable to move to the pump ON position due to interference in basin or other obstruction.	Position the pump or float switch so that it has adequate clearance for free movement.
	Insufficient liquid level.	Verify the liquid level is allowed to rise enough to activate float switch(es).
	3-phase motor winding failure or mis-wired motor.	Check resistance of motor windings. All three phases should have the same reading.
	Defective float switch.	Replace float switch.
	Obstructed impeller or volute.	Remove obstruction.
	Loose wiring connections.	Check and tighten all connections.
	Thermal overload tripped.	Wait for pump to cool to operating temperature.
Pump does not deliver proper capacity.	Discharge valve(s) partially closed or clogged.	Check the discharge line for foreign material, including ice if the discharge line passes through or into cold areas.
	Check valve partially clogged.	Raise liquid level up and down to clear; remove check valve to remove obstruction.
	Incorrect motor rotation.	1-phase internal capacitor models: contact factory. 1-phase exterior capacitor models: verify capacitor wiring in Figure 2, else consult factory. 3-phase: correct pump rotation direction. Refer to section 3-Phase Pump Rotation Verification .
	Total head is beyond pump's capability.	Route discharge piping to a lower level. If not possible, a larger pump may be required. Consult Liberty Pumps.
	Low liquid level.	Check liquid level.
	Obstruction in pump or piping.	Remove obstruction.

Table 2. Troubleshooting Matrix (continued)

Problem	Possible Cause	Corrective Action
Pump does not start and overload heaters trip.	Unintentional ground.	Turn off power and check motor leads for possible ground.
	3-phase motor winding failure or mis-wired motor.	Check resistance of motor windings. All three phases should have the same reading.
	Obstructed impeller or volute.	Remove obstruction.
Pump runs or hums, but does not pump.	Discharge line is blocked or restricted.	Check the discharge line for foreign material, including ice if the discharge line passes through or into cold areas.
	Check valve is stuck closed or installed backward.	Remove check valve(s) and examine for freedom of operation and proper installation.
	Gate or ball valve is closed.	Open gate or ball valve.
	Total head is beyond pump's capability.	Route piping to a lower level. If not possible, a larger pump may be required. Consult Liberty Pumps.
	Obstructed impeller or volute.	Remove obstruction.
	Pump is airlocked.	Turn pump off and let set for several minutes, then restart.
		Add baffle to reduce trapped air bubbles.
	Capacitor failure in control panel.	Check capacitors and replace if needed.
	Stuck/defective motor contactor in control panel.	Replace motor contactor.
Pump is not seated correctly in guide rail base.	Lift pump and re-position.	
Pump operates with control panel selector switch in Hand position but does not operate in Auto position.	Control circuits malfunctioning.	Check float switch level control or the alternator relay for issues. Replace as necessary
		Check control panel.
Pump runs, but does not turn off.	Pump is airlocked.	Turn pump off and let set for several minutes, then restart.
	Control panel selector switch in Hand position.	Set selector switch to Auto position.
	Float switch unable to move to the pump OFF position due to interference with the side of basin or other obstruction.	Position the pump or float switch so that it has adequate clearance for free movement.
	Control panel failure.	Check control panel.
	Defective float switch.	Replace float switch.
Motor stops and then restarts after short period but overload heaters in starter do not trip.	Pump operating on a short cycle due to basin being too small.	A larger basin may be required. Consult Liberty Pumps.
Pump cycles too frequently.	Improper float switch setting.	Adjust float switch setting.
	Check valve not installed, stuck open, or leaking.	Install check valve(s); remove check valve and examine for freedom of operation and proper installation.

Table 2. Troubleshooting Matrix (continued)

Problem	Possible Cause	Corrective Action
Pump operates noisily.	Piping attachments to building are too rigid.	Replace a portion of the discharge line with rubber hose or connector.
	Incorrect motor rotation.	1-phase internal capacitor models: contact factory. 1-phase exterior capacitor models: verify capacitor wiring in Figure 2, else consult factory. 3-phase: correct pump rotation direction. Refer to section 3-Phase Pump Rotation Verification .
	Pump is being run below minimum head requirement causing cavitation.	A different sized pump or impeller may be required. Consult Liberty Pumps.
	Foreign objects in the impeller cavity.	Clean the impeller cavity.
	Broken impeller.	Consult Liberty Pumps for information regarding impeller replacement.
Pump runs periodically when fixtures are not in use.	Check valve not installed, stuck open, or leaking.	Install check valve(s); remove check valve and examine for freedom of operation and proper installation.
	Fixtures are leaking.	Repair fixtures as required to eliminate leakage.
Repeated tripping.	Circuit protection underrated.	Check rating and replace with proper size.
	Current unbalance.	Check current draw.
	Other appliance on same circuit.	Pump requires separate circuit.
	Pump is connected to an extension cord or wiring is inadequate or compromised.	Have an electrician check for proper wiring.
	Improper voltage.	Have an electrician check all wiring for proper connections and adequate voltage and capacity.
	Obstruction in pump.	Remove obstruction.
	Incorrect motor rotation.	1-phase internal capacitor models: contact factory. 1-phase exterior capacitor models: verify capacitor wiring in Figure 2, else consult factory. 3-phase: correct pump rotation direction. Refer to section 3-Phase Pump Rotation Verification .
	Foreign matter buildup.	Clean motor housing.

Warranty

Liberty Engineered Products Limited Warranty

Liberty Pumps, Inc. warrants that pumps of its Engineered Product line are free from all factory defects in material and workmanship for a period of 18 months from the date of installation or 24 months from the date of manufacture, whichever occurs first, and provided that such products are used in compliance with their intended applications as set forth in the Liberty Engineered Products specifications and technical manuals. The date of installation shall be determined by a completed pump start-up report and warranty registration form.

A pump startup report, filled out by a qualified installer, is required for warranty to take effect. The report must be submitted within 30 days from the installation date and submitted through the Liberty Pumps website. During the warranty period, the manufacturer's obligation, and at its discretion, shall be limited to the repair or replacement of any parts found by the manufacturer to be defective, provided the product is returned freight prepaid to the manufacturer or its authorized service center, and provided that none of the following warranty-voiding characteristics are evident:

The manufacturer shall not be liable under this Warranty if the product has not been properly installed or maintained in accordance with the printed instructions provided; if it has been disassembled, modified, abused or tampered with; if the pump discharge has been reduced in size; if the pump has been used in water temperatures above those shown in the specifications; if the thermal overload(s) and seal moisture probe(s) have not been properly connected (where equipped); if the pump has been used in water containing sand, lime, cement, gravel or other abrasives; if the product has been used to pump chemicals or hydrocarbons; if the product has been moved from its original installation location, or if the label bearing the serial and code number has been removed.

Liberty Pumps, Inc. shall not be liable for any loss, damage or expenses resulting from installation or use of its products, or for consequential damages, including field labor costs, travel expenses, rental equipment, costs of removal, reinstallation or transportation to and from the factory or an authorized Liberty Pumps repair facility.

There is no other express warranty. All implied warranties, including those of merchantability and fitness for a particular purpose, are limited to 18 months from the date of installation or 24 months from the manufacturing date. This Warranty contains the exclusive remedy of the purchaser, and, where permitted, liability for consequential or incidental damages under any and all warranties are excluded.

<https://www.libertypumps.com/lep/dom/Services/Warranty-Startup-Form>